

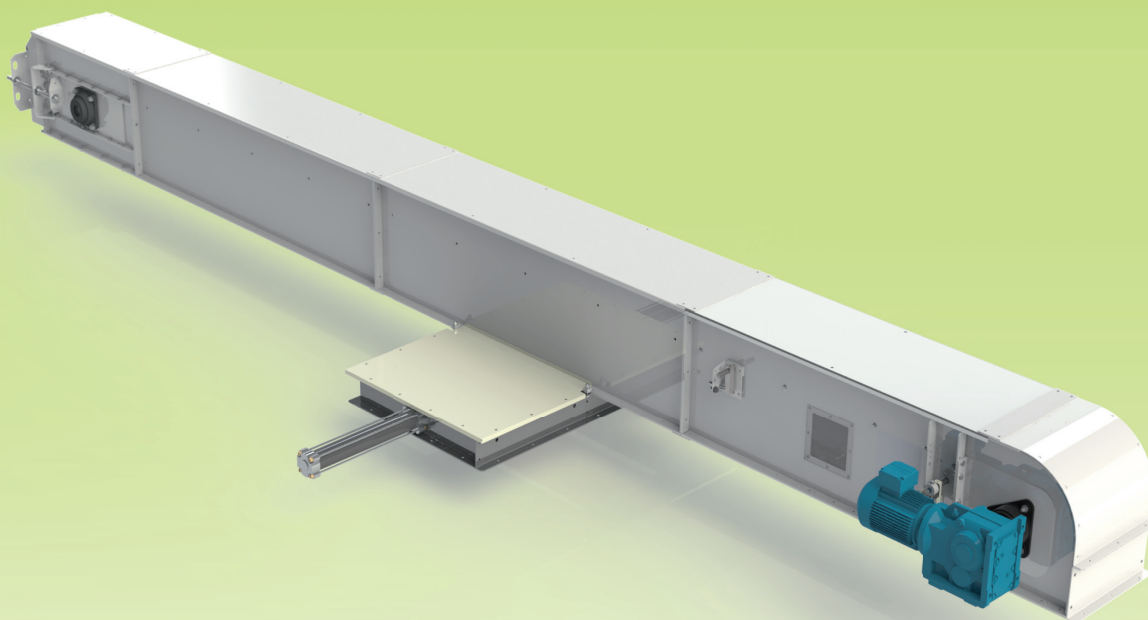

Handling & Dedusting



Bucket Elevators



A bucket elevator is designed for handling and extracting granular and powdery products over a vertical linear trajectory.

Our wide range of standard elevators allows capacities up to 1600 m³/h.

For applications not included in the range, our Design Offices are qualified to develop specific elevators meeting all requirements.

Features

- Protection of the head ejection area against abrasion
- Adjustable and flexible outlet flap
- Dismountable duct
- All types of buckets and belts or chain
- Possible slow speed for fragile products



Bucket Elevators

Options and safety

Options

- Optimized discharging foot
- Suction intake or built-in dedusting filters
- Gradual progress for maintenance
- Feet above ground for easy maintenance
- Refeeding inlet

Safety devices

- ATEX compliance on demand
- Belt misalignment control
- Rotation control
- Clogging detection
- Product flow detection

Solutions against explosion risks



Explosion vent
at elevator head

STOLZ solutions to limit explosion risks:

- Use of antistatic (ISO284) and self-extinguishing (ISO340) belts
- Fitting of explosion vents (to be specified according to each elevator: installation, capacity, KST product...)
- Dedusting at feeding inlets and outlets
- Misalignment belt control
- Rotation control
- Bearing temperature control (option)
- Inert gas injection



Bucket
elevator



High capacity elevator head
(1600 m³/h, height 65 m, 2x200 kW)

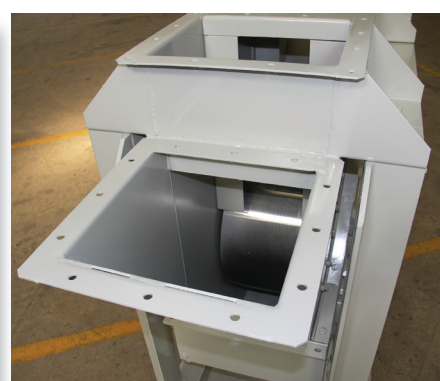

Refeeding
inlet

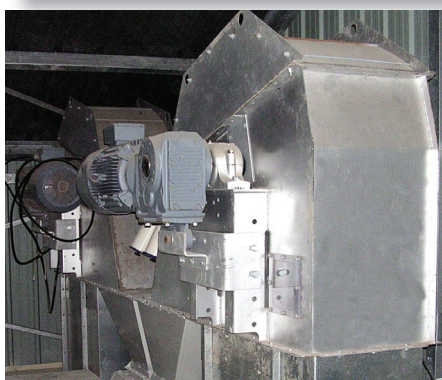

Galvanized
elevator



ATEX
elevator



Elevators
with discharge suction intakes

Chain Conveyors

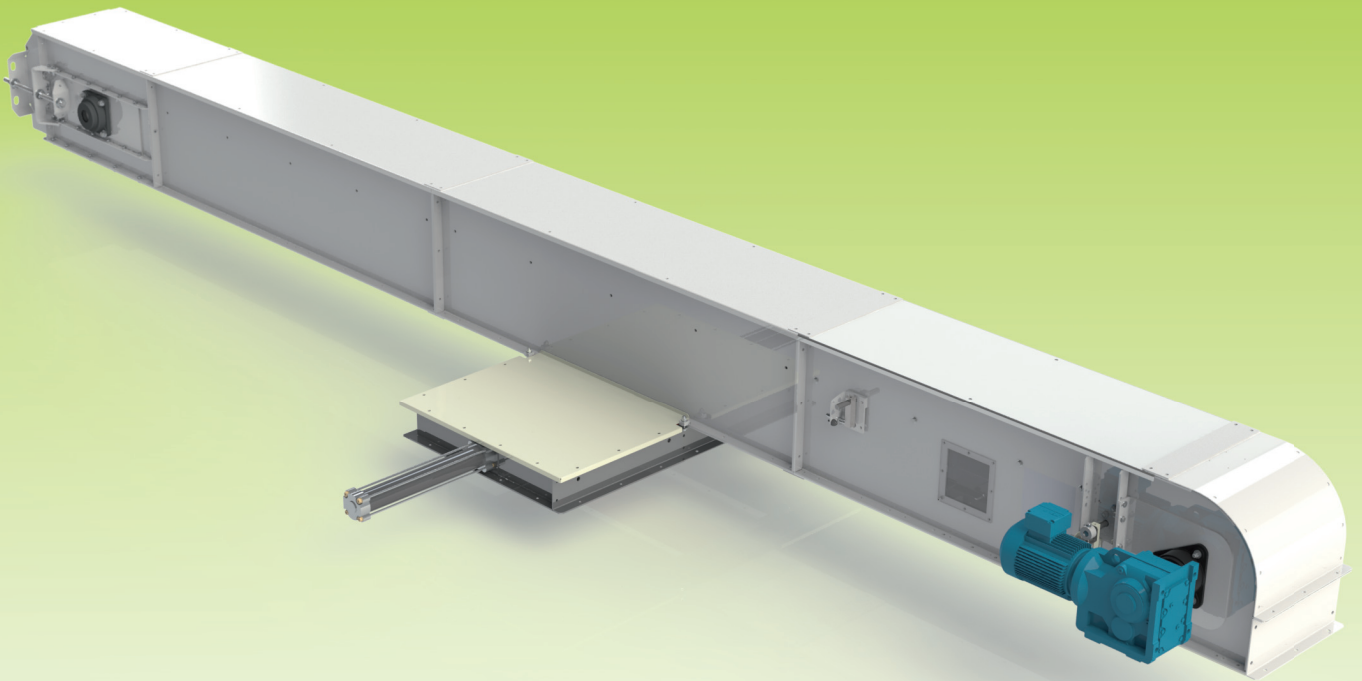

A chain conveyor is designed to handle and extract of granular and powdery products over a sloped, horizontal or linear trajectory.

Our new range of chain conveyors covers capacities up to 530 m³/h i.e. 400 t/h on cereal base SW 0,75. The complete range allows capacities up to 1600 m³/h.

For applications not included in this range, our Design Offices are qualified to develop specific conveyors meeting all requirements.



Chain Conveyors

Features and options

Improved design

- Sprocket with dismountable teeth.
- Block screw pulleys
- Rationalized chains:
 - Chains including Stolz forged links, with breaking strengths from 22 to 100 T
 - ISO standardized mechanical chains, with breaking strengths from 11 to 31 T
- HMW Return rails, and HMW plates every 2 pitches reducing the wear and sound level
- Limited references for spare parts

Improved discharge

Different possible axis height of pinions and foot pulleys according to the chain type optimizing the conveyor discharge. Without this system, some chains lift up over a few meters before discharge head preventing a complete discharge of the unit. The chain trajectory is then adjusted as close as possible to the bottom.

As an option, a rounded casing follows the chain trajectory at foot reducing the product retentions.

Safety devices

- ATEX compliance 94/9/CE on demand
- Rotation control
- Overflow detection
- Product flow detection

Design for limited product retention

- Rounded head top profiles
- Optional rounded moving tensioning casing at foot
- Adjustment of trajectories according to chain types
- Bottom replacement valves
- Complete high Density Polyethylene chains with plates and side polyurethane scrapers
- Vertical spacers
- Shaped return rails

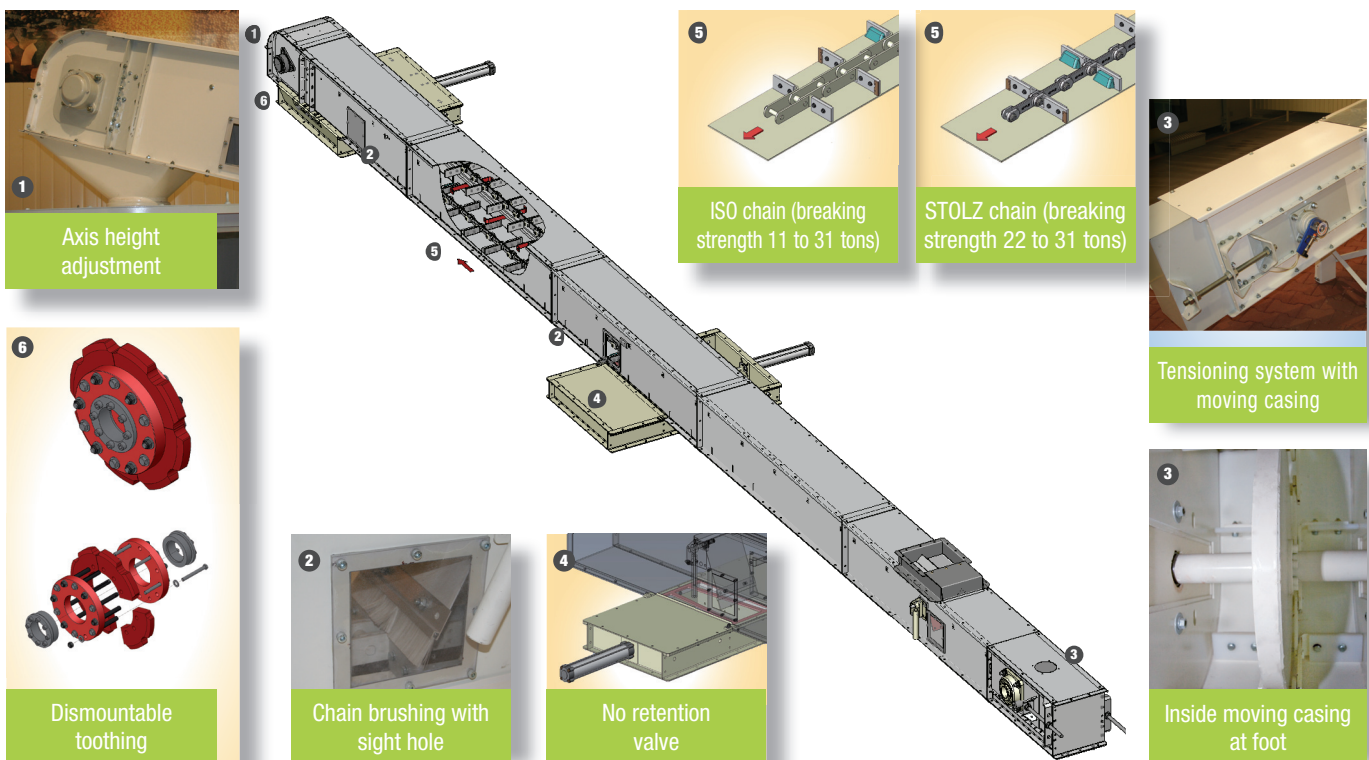

Curved chain conveyors J or Z shapes

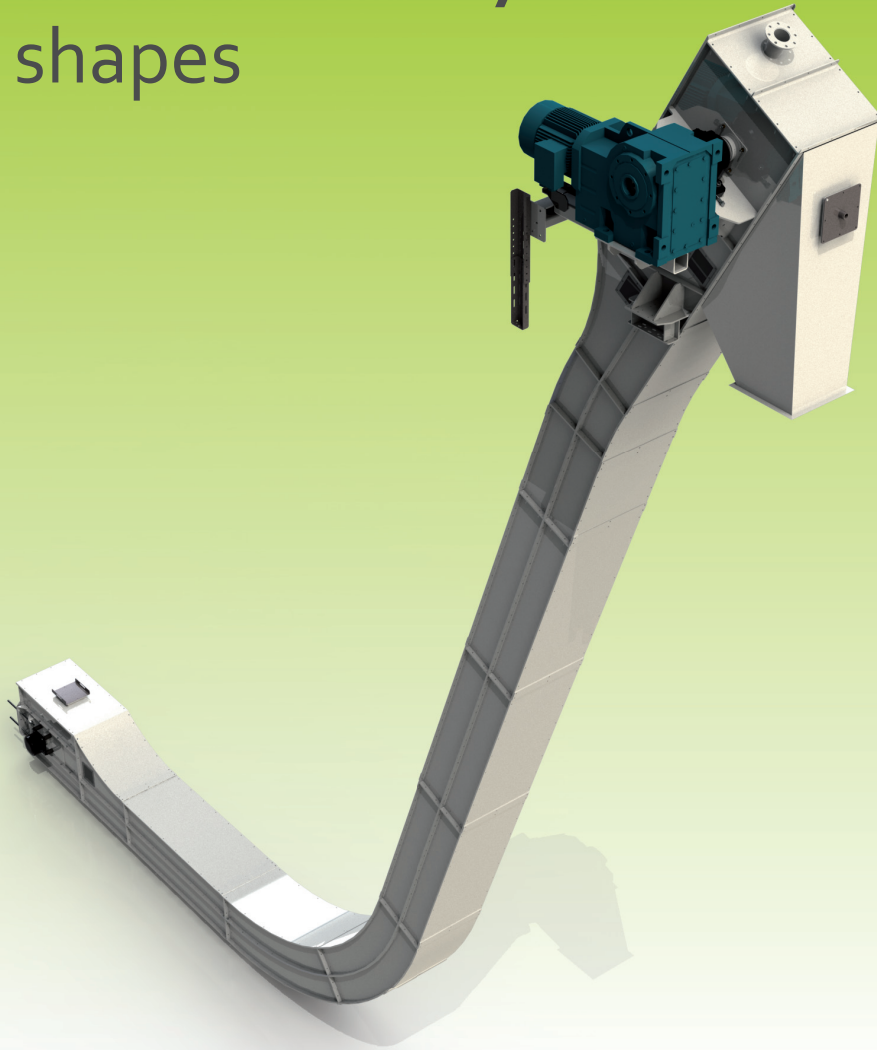

Our range of curved chain conveyors with long inclination is convenient and useful for industries with high explosion risks.

In risk assessment reports curved chain conveyors are preferred for product lifting to standard systems with bucket elevators horizontally fed by belt, screw, or chain conveyors.

Explosion risks are reduced significantly thanks to the slow conveying speeds of chain conveyors. According to the NFEN1127-1 standard at a speed below 1 m/s no spark is produced by a shock between 2 metallic parts. The conveying speeds are usually adjusted between 0.2 and 0.6 m/s for chain conveyors and between 2 to 3 m/s for bucket elevators.



Curved chain conveyors J or Z shapes

Characteristics

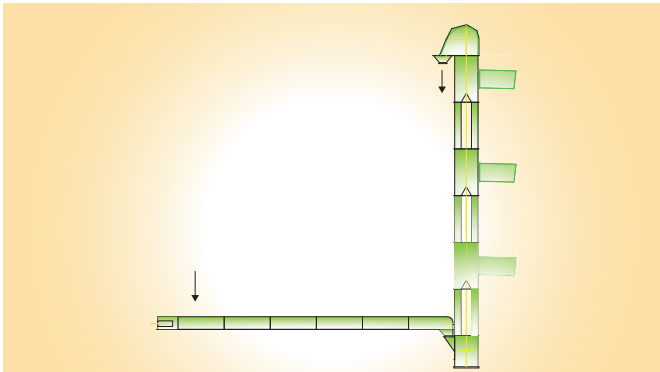

Lifting of product with a horizontal conveyor then a bucket elevator

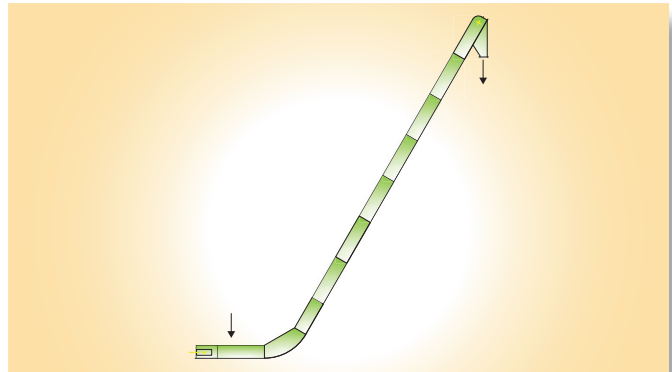

Lifting of product with a curved chain conveyor

Principle of curves

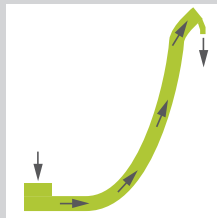

Shape « Z »

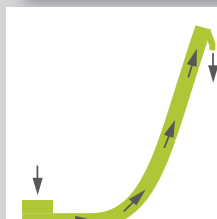

Shape « J »

In addition to the technical and legislative aspects, elevators suitable to industries with high explosion risks are costly by reason of their explosion protective systems.

Beside the «Z» curved chain conveyors (the most commonly used), we have also designed the «J» shape conveyors.

One of the advantages to have a single curve instead of 2 is to allow the use of motors with lower power, thus reducing the required power consumption. The upper curve generates significant frictions requiring an increase of motors torque. By removing the upper curve we are also increasing the lifetime of mechanical elements thus subject to less stress.

These advantages will offer our customer lower running costs.

Our range has capacities from 20 up to 300 m³/h varying according to inclination.



Curved chain conveyor



Curved chain conveyor head

Screw Conveyors

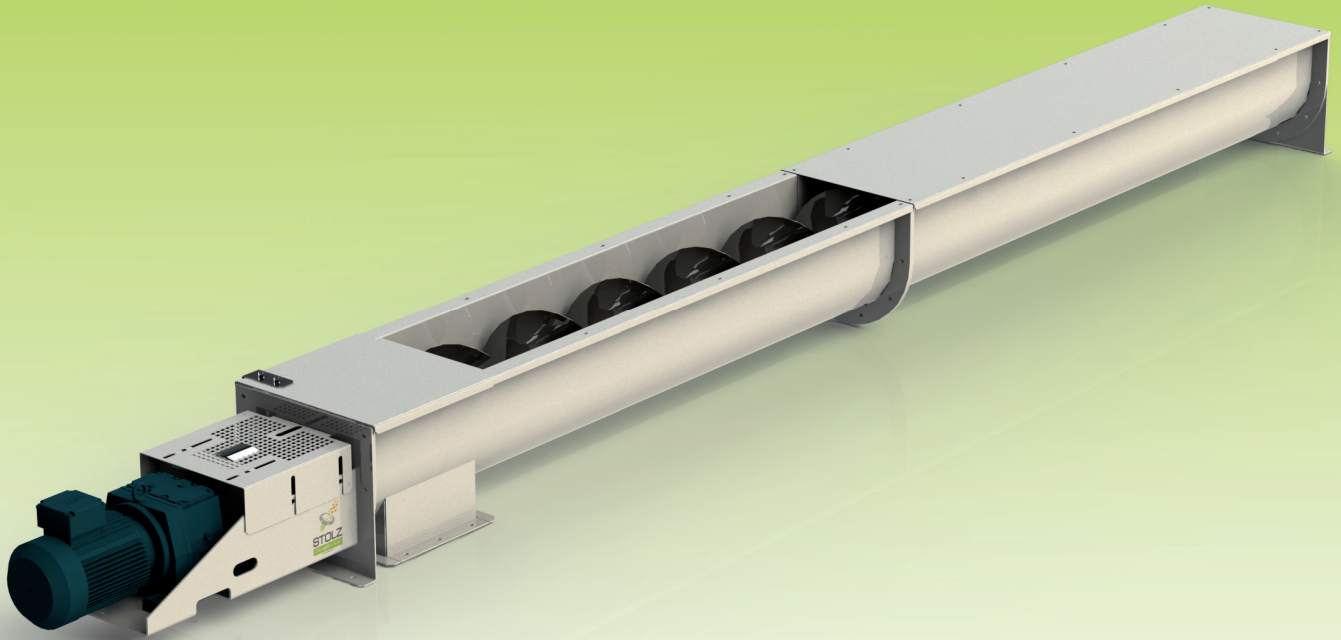

The screw conveyor is designed using the worm type conveyor principle for handling and extracting or dosing granular and powder products. The product is handled horizontally or sloped in a linear way.

Our wide range of standard worm type conveyors provides capacities up to 300 m³/H.

For applications not included in this range, our Design Offices are qualified to develop specific screws meeting all requirements.



Screw Conveyors

Features and options

Types

2 types of screw conveyors :

- Trough
- Tubular

Conical extracting screws

Spires

The spire usually includes a tube on which a continuous thread is welded.

They may be with pallets or ribbon.

The pitch may be :

- Regular for product conveyance
- Progressive for product extraction

Features

- Continuous pitch, with pallets or ribbon
- Regular, progressive or conical pitch
- Synthetic intermediate bearings
- V ring joints or felt sealing

Options

- Bronze or cast bearings, with or without wearing shell
- Sealing by gland with braids
- Spire height adjustment

Accessories

- Fast closing flap for dosing
- Valve with limited residues
- Bottom doors

Safety devices

- ATEX compliance on request
- Rotation control
- Overflow detection
- Product flow detection



Screw conveyors



Screw feeders



Valve with limited residues

Belt Conveyors

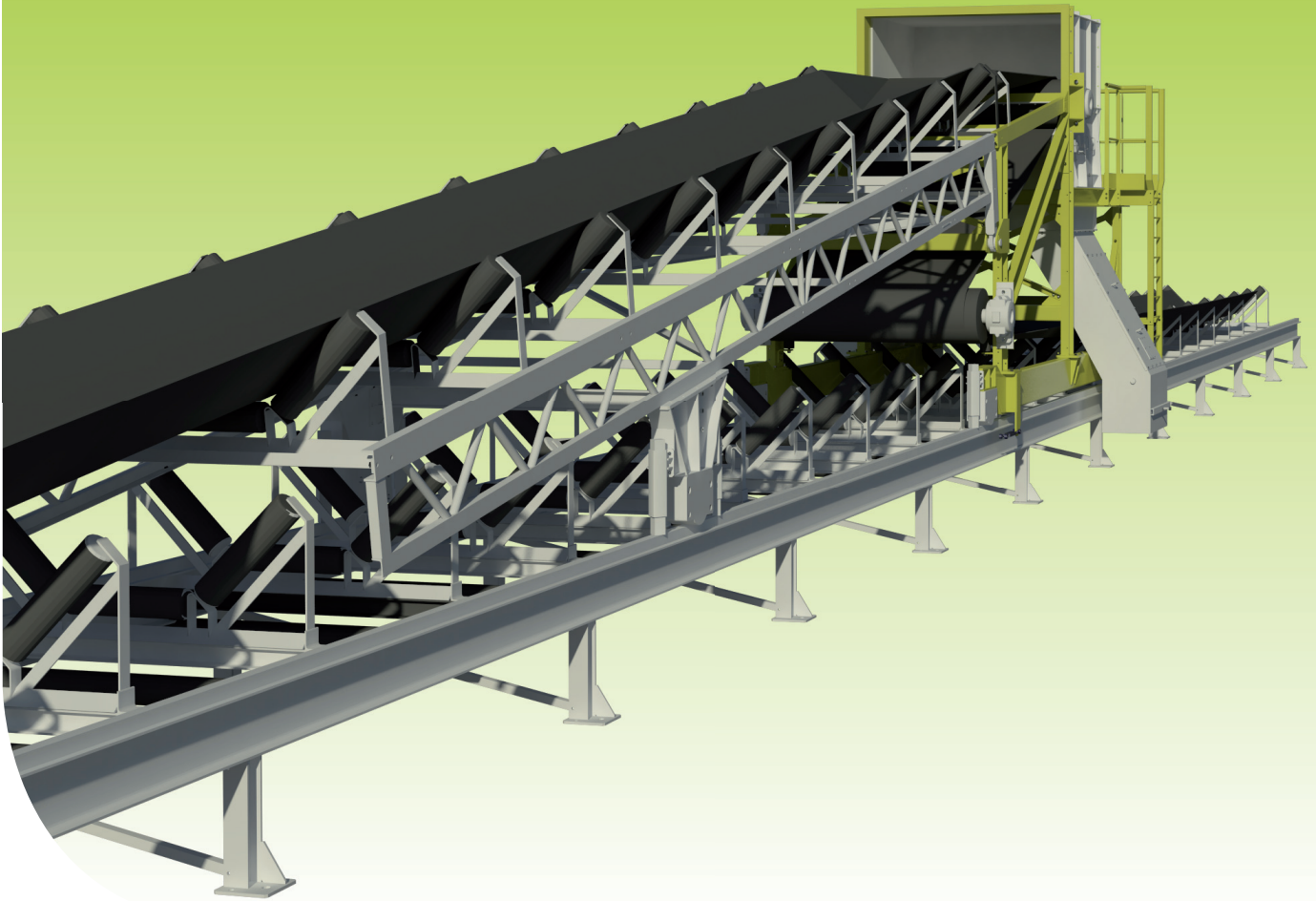

The belt conveyor is designed to handle and extract granular and powdery products. The product is handled in a linear way over long distances, horizontally or sloped.

Granular or powdery product handling, fragile products within a range with capacities up to 1600 m³/h.

For applications not included in this range, our Design Offices are qualified to develop specific conveyors meeting all requirements.



Belt Conveyors

Features and options

Features

- Pulley and belt scrapers
- Magnetic protection
- Automatic or screw tension with counterweight
- Antistatic (ISO284) and self-extinguishing belts (ISO340)
- All types of rollers
- Discharge hopper with 1 or 2 outlets

Accessories

- Weather protection
- Mobile tripper, 1 or 2 outlets

Options

- Dedusting filter at feeding inlet or discharge outlet
- Tripper with built-in dedusting filters
- Specific scrapers

Safety devices

- ATEX compliance 94/9/CE on demand
- Belt misalignment control
- Rotation control
- Overflow detection
- Product flow detection
- Emergency stop with cable

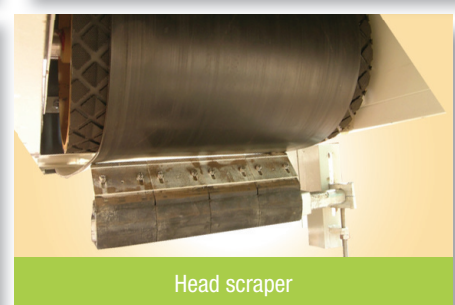

Canal Barges loading



STOLZ canal barges loading ducts derive from its know-how and years of experience regarding ship loading.

Our barges loading duct has been designed to provide high reliability, low operating costs and a limited environment impact.

As a standard, they can reach 600 t/h. Our barges ducts can load barges from class I (type Feycinet – 250t) up to Va (type Rhenan – 3000 t).

Accessories

- Driver's cab
- Driver's seat



Canal barges loading

Features

- Moved by electrical cylinders (hydraulic as an option)
- Low running cost
- Quick installation
- Easy maintenance
- Smooth movements
- Low environmental impact (no oil, low noise level)
- Watertight and dust proof duct with optional ceramic and polyamid lining.
- Easy replacement of wearing parts (standard components)
- Remote or wire controlled

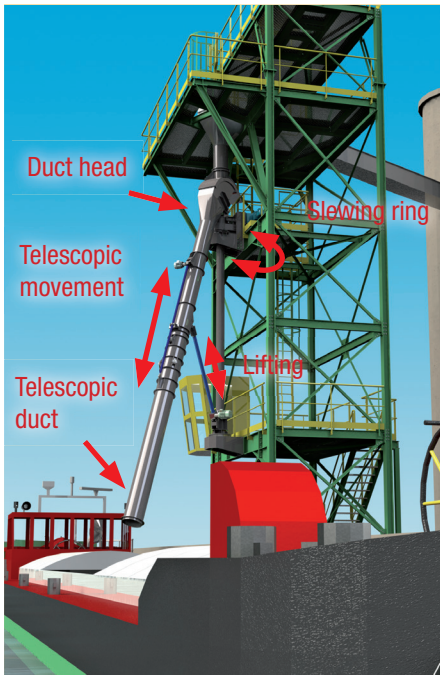

Electrical cabinet of automation

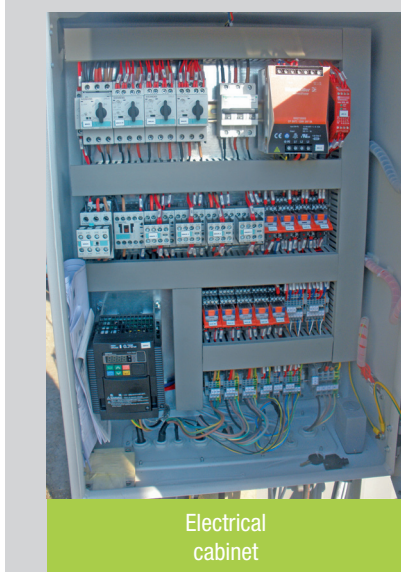

The electrical cabinet for loading control is provided to use the equipment in optimum conditions.

Smooth rotation stops and start up control is one of the main features of the cabinet; it bans quick reversed movements.

Such control lowers the load on the slewing ring and limits the mechanical strains.

The unit can be driven in 2 ways:

- remotely through a wire or remote control
- locally, using buttons on the front face of cabinet to replace the remote control if required.

Such equipment operating without hydraulic power leads to significant energy saving.

The consumed power is only the power required for the crane movement; this technology avoids hydraulic units operating without product and facilitates the maintenance.

Chain reclaimers



Purpose

The chain reclaimer is designed to handle and extract bulk granular products in flat bottomed silos.

At filling stage, it is used to optimize storage capacities through scraping flat bottom.

At discharging stage, it is designed to scrap the product towards the reclaiming conveyor.

Features

- Assisted automated operation
- Open girder designed to prevent product retention

Safety devices

- Atex Area 22 on request
- Autonomous safety devices monitoring
- Safe positioning of chain reclaimer to give access to storage area



Canal barges loading

Features

- Moved by electrical cylinders (hydraulic as an option)
- Low running cost
- Quick installation
- Easy maintenance
- Smooth movements
- Low environmental impact (no oil, low noise level)
- Watertight and dust proof duct with optional ceramic and polyamid lining.
- Easy replacement of wearing parts (standard components)
- Remote or wire controlled

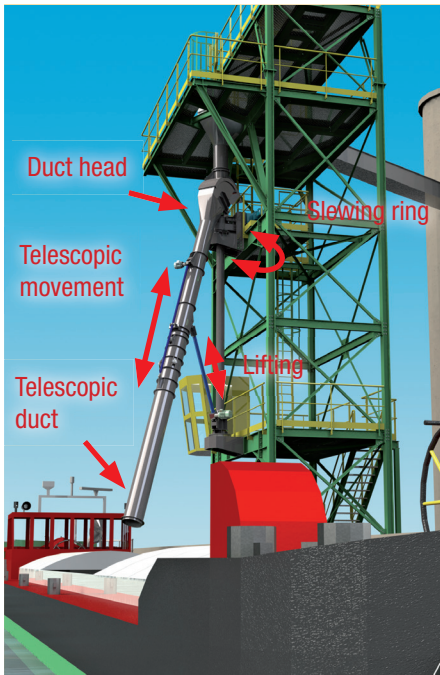

Electrical cabinet of automation

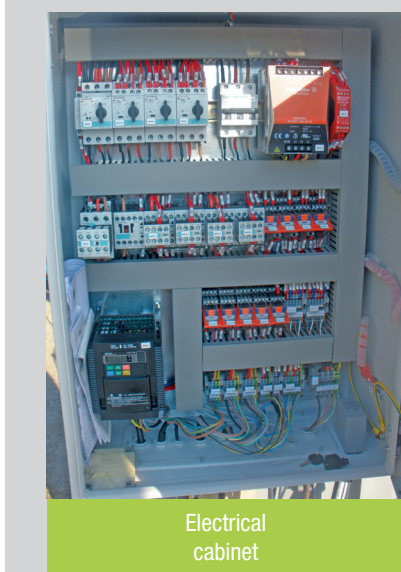

The electrical cabinet for loading control is provided to use the equipment in optimum conditions.

Smooth rotation stops and start up control is one of the main features of the cabinet; it bans quick reversed movements.

Such control lowers the load on the slewing ring and limits the mechanical strains.

The unit can be driven in 2 ways:

- remotely through a wire or remote control
- locally, using buttons on the front face of cabinet to replace the remote control if required.

Such equipment operating without hydraulic power leads to significant energy saving.

The consumed power is only the power required for the crane movement; this technology avoids hydraulic units operating without product and facilitates the maintenance.



Pneumatic Transfer

Handling of granular or powdery products by forced air or vacuum.

Features

- Speed in accordance with product fragile
- Different types of rotary valves and sealing chambers
- Round, square, or rectangular sections
- Specific air release piping



Pneumatic conveying

Options and safety devices

Options

- Anti-wearing ceramic protection
- Removable cast iron, Ni-Hard bends
- Pressured gasket for tightness at shaft crossing opening
- Regulation on programmable automaton
- Air treatment by heater and dryer

Safety devices

- Pressure switch, temperature sensors, regulation
- Counter current inerting
- Rotations sensors
- Overflow sensors
- Equipotential bonding



A pneumatic transfer supply by cyclone

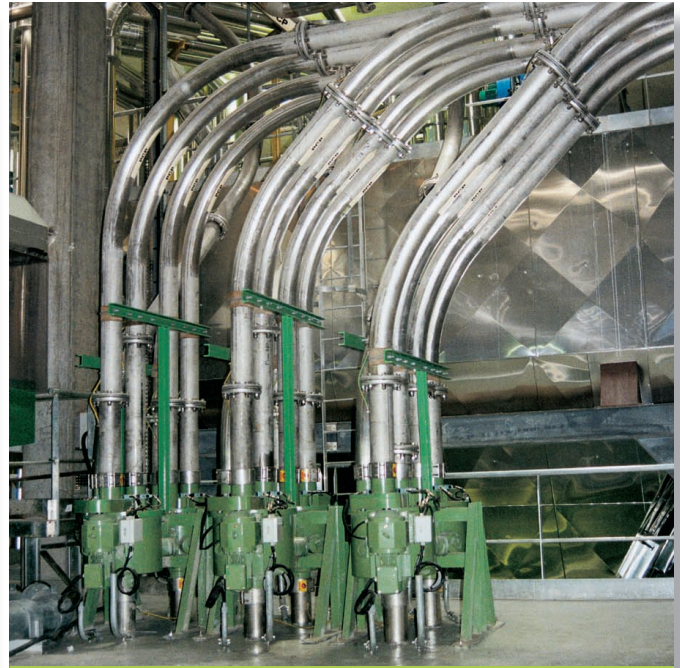

Pneumatic transfer

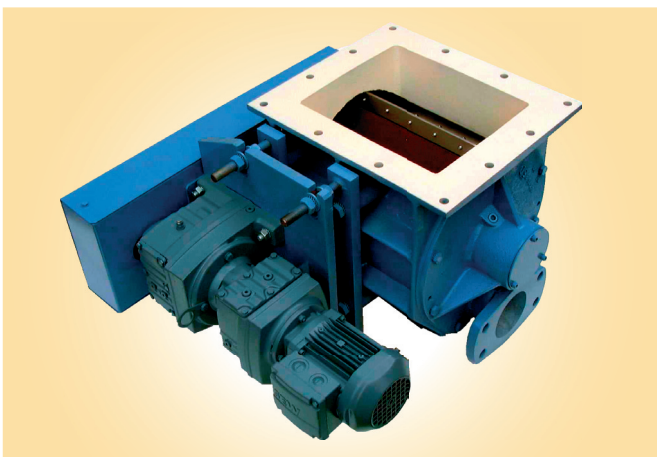

Rotary valve



Pneumatic transfer

Swing spout distributor

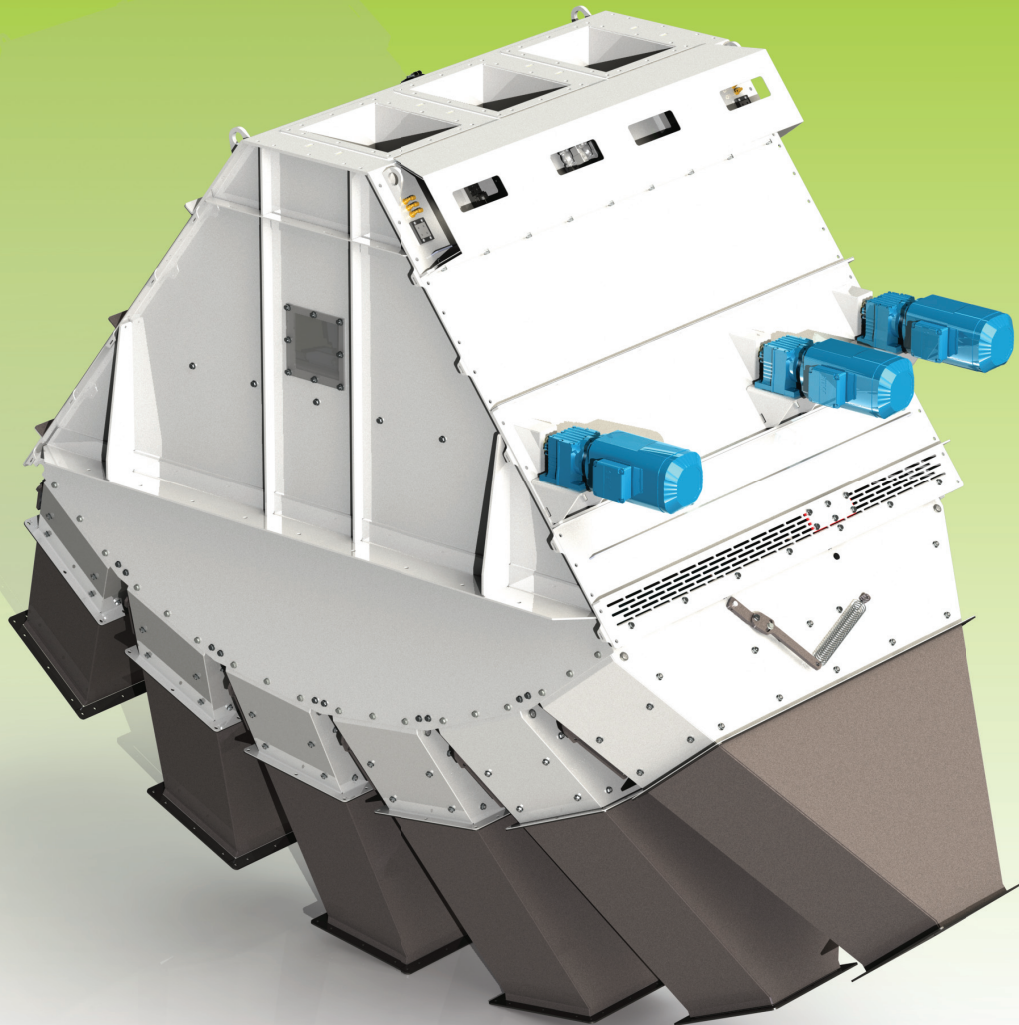

The STOLZ swing spout distributor directs several flows of product (powdery or granular) to different circuits at a maximal capacity of 300 tons/hour. Its design limits the danger of explosion or cross contamination.

- Bottom cleaning by air blowing associated to centralized air suction
- Swing spout lined with removable wearing plates
- Built in STOLZ automaton with control cabinet

Characteristics :

- Independent swing spout controlled by motorized worm screws
- Driving screws fitted with individual cleaning systems
- Swing spout with upper and lower sealings to reduce dust emissions inside the distributor



Swing spout distributor

Limited Risk version



Swing spout distributor and control cabinet

The ATEX directive and some national regulations constrains industrials to take safety measures in silos to limit the effects of an explosion and to stop its propagation.

The STOLZ swing spout distributor has the advantage to insulate each non used outlet allowing :

- to avoid any risk of cross contamination
- to dramatically lower the danger of explosion transfer between circuits

Every outlet is fitted with an individual seal flap to avoid communication between the different circuits.

The opening of the outlet seal flap is individually controlled by a pneumatic cylinder.

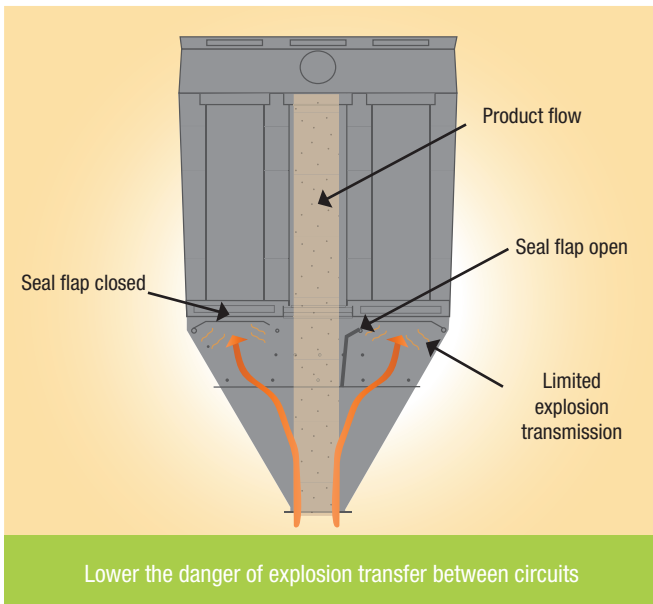

Lower the danger of explosion transfer between circuits

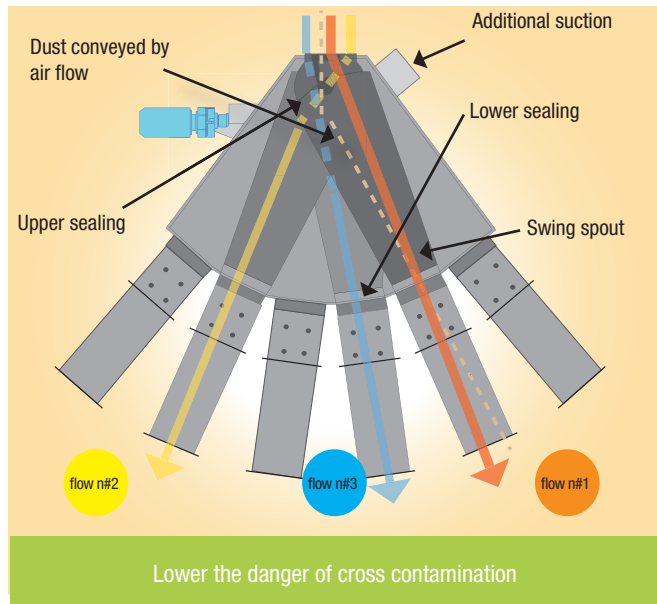

Lower the danger of cross contamination

Automation : control cabinet

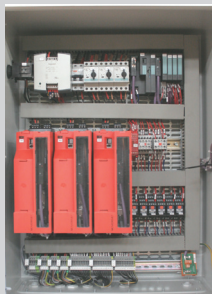

STOLZ include with the swing spout distributor a control cabinet supporting the following features :

- a management automaton allowing to pilot and stop the swing spout at the required positions
- a remote control by Profibus DP communication (AS-i or wired network supplied as an option)
- a proximity control monitored by the automaton for a local control

2 or 3 direction boxes

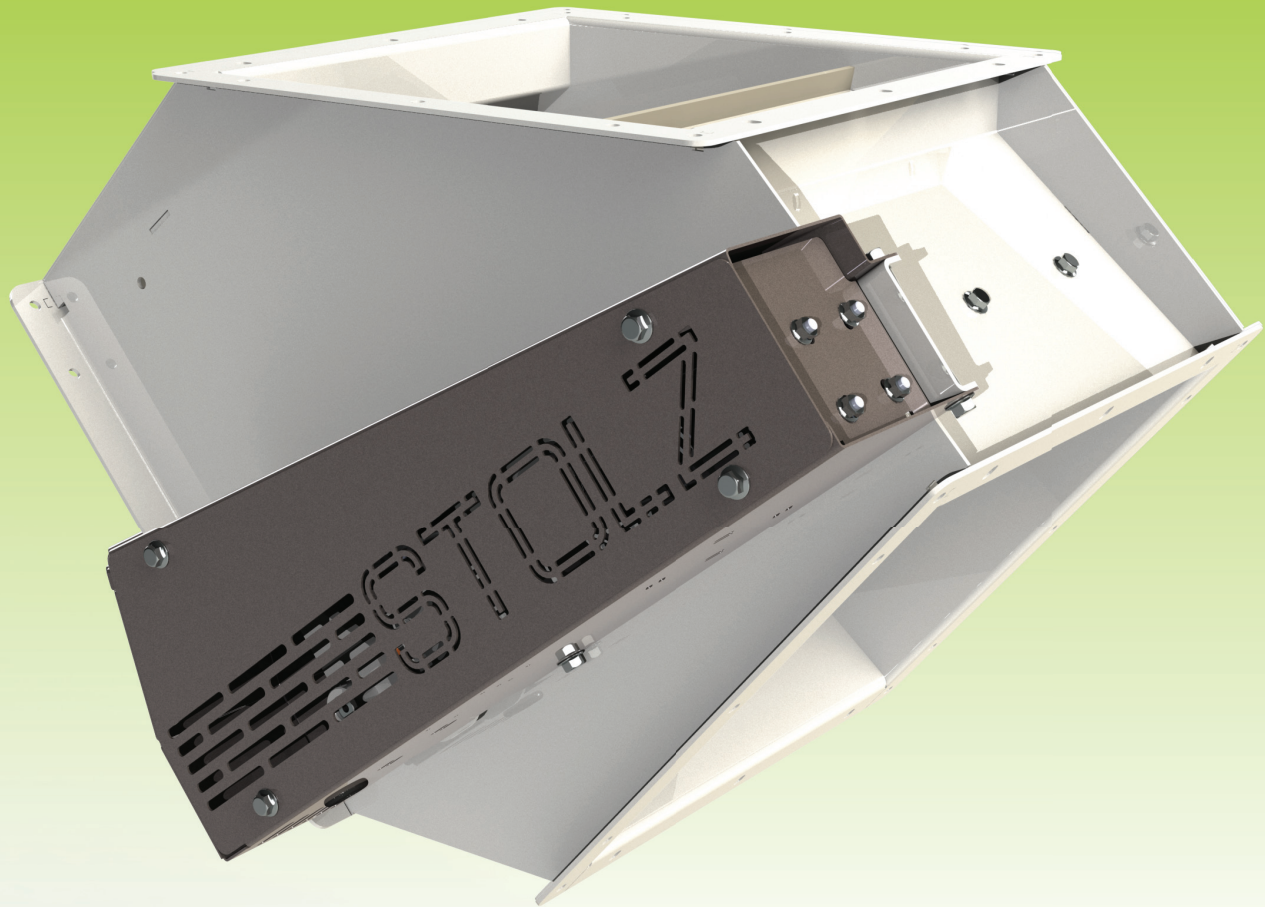

STOLZ 2 or 3 directions boxes are part of our range of equipment for gravity handling dedicated to the design of complete systems for flow direction of granular or powdery products in round or square sections.

A wide range of equipment that slows down, recenters, levels, limits the damages to the conveyed product.

Designed for use with healthy product (free of wastes, stones, wood etc. ...) our 2 or 3 directions boxes can be equipped with manual or pneumatic controls and (inductive) detection.



2 or 3 directions boxes

Features

- High resistance to abrasion of the valve
- Tilting around a horizontal axis
- Assembly mounted on bearings and keyed trunions
- Complete peripheral seal
- Polyethylene Side scrapers
- Remotely activated valve by pneumatic cylinder
- Built-in distributor
- Side inspection door

Operating principle

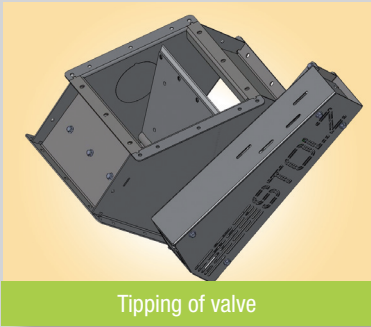

Tipping of valve

A sheet valve with high resistance to abrasion and high thickness pivots around a horizontal axis. It is assembled on the box with two keyed journals and mounted on bearings.

The valve is remotely activated by a linear pneumatic cylinder with built in distributor under full housing. In the case of a manual control, a rocker arm can change its position. All our boxes are equipped with a side inspection door.

	Type	Diagram	Section (mm)	Pneumatic Control	Manual Control	
B2D	Flat Base		200 ²	VB Ø50-150	Rocker arm type 400	
			250 ²			
			300 ²			
			350 ²			
	Symmetrical 45°		200 ²	VB Ø50-150	Rocker arm type 400	
			250 ²			
			300 ²			
	Symmetrical 40°		350 ²	VB Ø63-150	Rocker arm type 500	
			400 ²			
			450 ²			
	Symmetrical 60°		200 ²	VB Ø50-150	Rocker arm type 400	
			250 ²			
Asymmetrical 45°		300 ²	VB Ø50-150	Rocker arm type 400		
		350 ²				
		400 ²				
		Asymmetrical 40°		450 ²	VB Ø63-150	Rocker arm type 500
				500 ²		
Asymmetrical 60°		200 ²	VB Ø50-150	Rocker arm type 400		
		250 ²				
		300 ²	VB Ø63-150			
		350 ²				
B2D under CC	Symmetrical 45°		240 x 600	VB Ø50-150	Rocker arm type 400	
			320 x 800			
	Symmetrical 40°		410 x 800	VB Ø63-150	Rocker arm type 500	
			530 x 800			
B3D	Symmetrical 45°		300 ²	VB Ø50-150	Rocker arm type 400	
			350 ²			
	Symmetrical 40°		400 ²	VB Ø63-150	Rocker arm type 500	
			450 ²			
			500 ²			

Sampler



The sampler is designed for volumetric sampling on granular and powdery lines. It is installed in a product flow to provide a representative sample. For instance, it can be mounted on a gravity pipe for products with a specific weight above 0.35 without air disturbance.

Equipped with a pneumatic actuated cylinder, our sampler can be supplied with a control box. The contained sample also guarantees the operator's safety.

Features:

- Robust design for industrial use and high flow rates : up to 600 samples in 24 hours – 365 days/year
- Made of blasted stainless steel AISI 304L
- Standard steel piston for a very long mechanical service life
- Guides provided by PET rings loaded with solid lubricant



Sampler

Options and principle

Cleaning :

Fast removal of the pneumatic actuator provides a direct access to the piston, enabling its extraction, cleaning and body cleaning. The body consists of two removable parts thus optimizing the accessibility for cleaning.

Compliances:

- machines directive
- Atex compliance as an option
- EC regulation on request

Operating principle

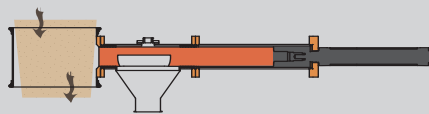

Before sample

The cylinder rod comes out while pushing the piston towards the product flow of outward. This movement is combined with the piston rotation to bring the cavity upward when sampling.

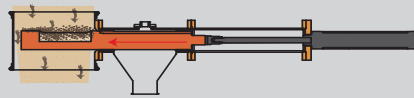

During sample

The product builds up inside the hole. Once the sample has been completed the cylinder retracts while pulling the piston loaded with the product sample with a reverse rotation movement.



After sample

The product flows into an outlet hopper that may be connected directly to the collecting pipe.



Operating piston

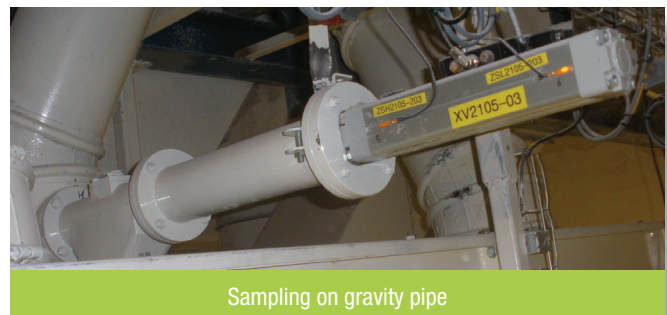

Sampling on gravity pipe

Control box

Our control box provides several operation modes :

- Manual mode: This mode enables you to start a sampling cycle when pressing a push button. After a configurable waiting time the sampler returns to initial position
- Automatic mode. This mode launches sampling cycles at regular intervals, adjustable for a total time which can also be set.

The available settings are provided to operate on :

- the sampler output time
- the sampling frequency
- the sampling cycle time

Valves

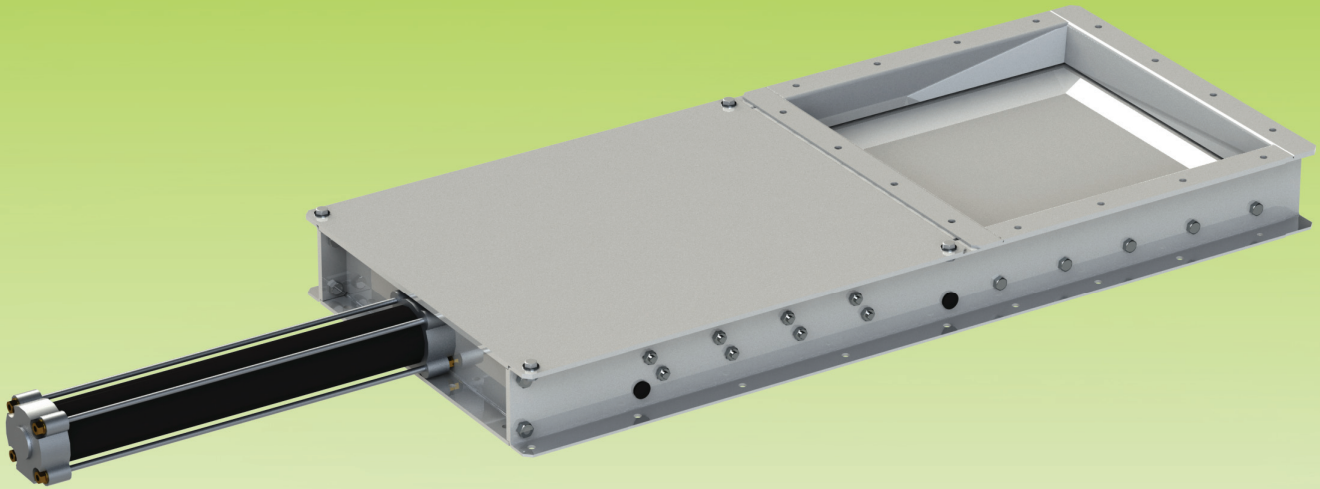

STOLZ valves are part of our range of equipment for gravity handling dedicated to the design of complete systems for flow direction of granular or powdery products in round or square sections.

A wide range of equipment that slows down, recenters , levels , limits the damages to the conveying product.

STOLZ valves are designed to isolate different product circuits.



Valves

Range and controls

Our wide range can meet numerous requirements such as:

- valves under cells
- Helmet valves under cells
- No retention valves under chain conveyor
- Standard valves under chain conveyor
- valves on vertical walls

Almost all our valves can be supplied with:

- manual control with wheel or chain sprocket wheel
- pneumatic control on board distributor
- electric drive with torque limiter

The opening-closing detection is carried out by two inductive sensors.

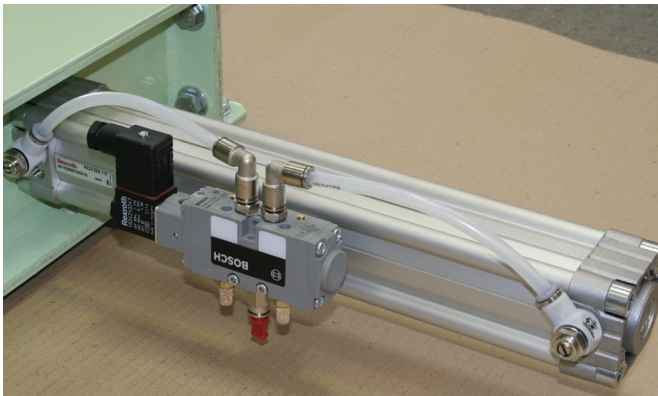

Pneumatic cylinder

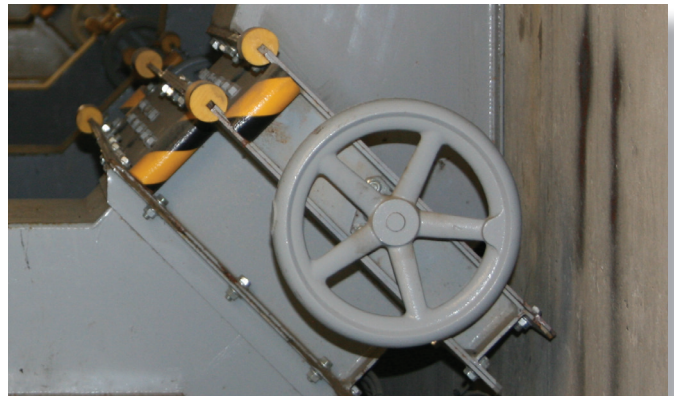

Manual control

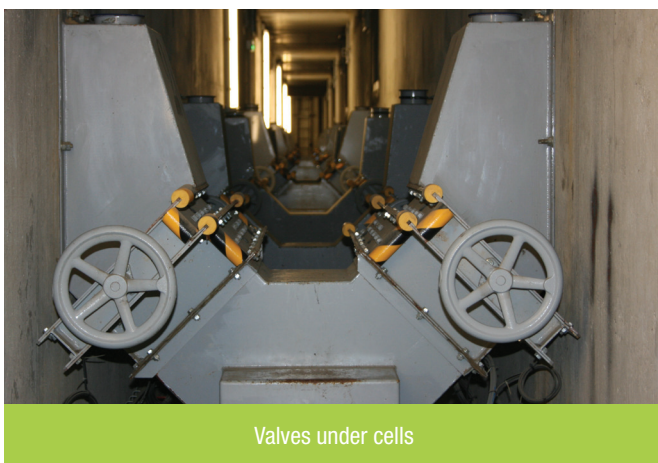

Valves under cells

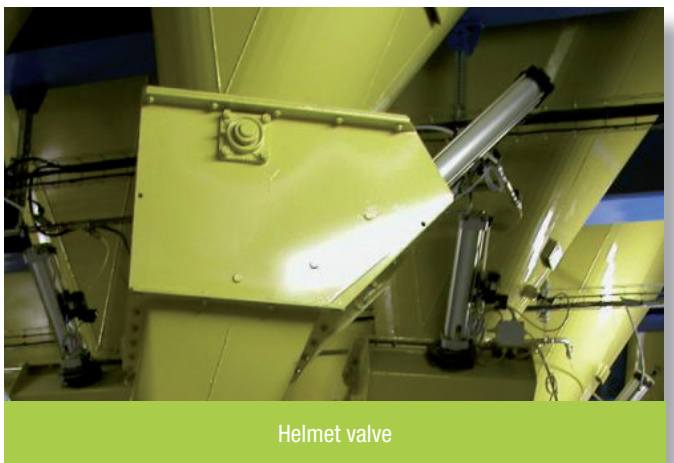

Helmet valve

Fitting of a valve in the circuit

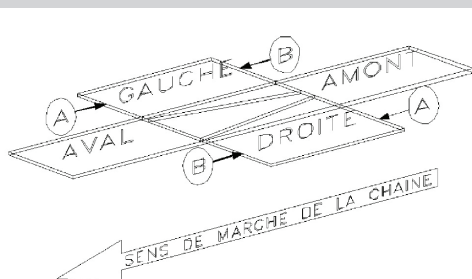

Diagram of implantation

Mounting rules of valves are the same as those applicable to pipes (including for valves marking).

For valves under chain conveyor, it is necessary to specify the direction of assembly of valves and the location of the steering wheel according to the diagram shown on the left.

Pad Filters

CFP



Features

- Limited size for filtering area up to 150 m²
- Cleaning by counter current compressed air (tank does not require to be proofed again)
- Filtering pads adapted to the different kinds of products

Uses

- Silo decompression
- Pneumatic handling
- Cooling
- Grinding
- Bulk pit cleaning
- Cleaning of dust emission points on handling equipment (inlets, outlets,...)
- Bags unloading



Pad filters CFP

Features and options

Monitoring of filtration processes



Our sequencer is designed to control and monitor the pads and sleeves filters cleaning.

The solenoid valves are inserted into the sequencer.

This device is set according to the required use.

The sequencers are fitted with a ΔP module, controlling the start-up and stop of the cleaning operation. This device saves air and improves filtration.

It is equipped with :

- High and low ΔP alarms (with relay output)
- A ΔP threshold and an input for fast running
- A control of an electric fault
- An analog output for the remote monitoring of ΔP measurement
- 2 relay outputs to report faults and control the cleaning.



Centralized dedusting



Pads filter for silo depressurization



Bag emptying pad filter

Regulation

- Atex compliance on request
- Compliance to the regulations in force and to specific requests in regards of dust discharge
- Air tank compliance to the pressure equipment directive does not require to be proofed again



Anti-explosion risk solutions

- Use of antistatic filters
- Installation of explosion vents (to be specified according to: implementation, capacity, product KST,...)
- Installation of a decoupling valve
- Reinforcement of the filter
- Clogging monitoring of the filter by measuring the Delta-P
- Control of the state of filters
- Wastes control
- Inert gas injection

Sleeve Filters

CFM



Features

- High filtration capacity: up to 210 m² as standard
- Cleaning by counter current compressed air (tank does not require to be proofed again)
- Filtering sleeves adapted to the different kinds of products
- Shapes designed to limit product retention
- Control of the filtering process of product similar to pads filters

Uses

- Centralised cleaning
- Grinding
- Bulk pit cleaning
- Bulk loading cleaning
- Cleaner - Drumschalper



Sleeve Filters CFM

Our different solutions

Dust sensor

The installation of a dust sensor at a cleaning filter outlet can detect an abnormal amount of dust through an air flow.

Some versions can also carry out measurements of atmospheric wastes.

In the first case, it can :

- Detect a damaged filter
- Detect an explosive atmosphere (Atex)

In the second case, it can also check the compliance to the rules relating to dust wastes.

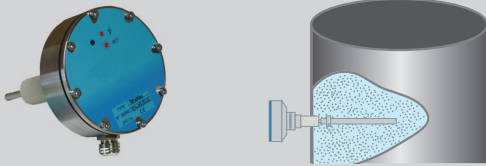

Low capacity sleeve filter

That range of sleeve filters has been especially designed to meet the requirement regarding :

- Silos decompression
- Pneumatic transfer
- Mixer decompression

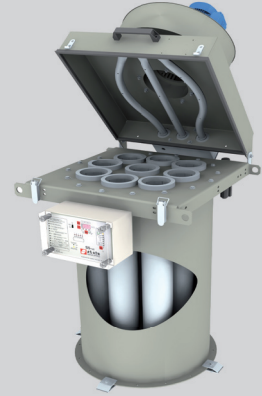

High capacity sleeve filter



1400 m² sleeve filter



Sleeve filter unit for pneumatic transfer

Cyclofilter principle



Galvanized cyclofilter with sleeves

The advantage of the cyclonic effect is a pre-separation of the biggest particles that could damage the sleeves.

Because of its more resistant round shape it can resist to pressure-vacuum :

- Safe installation for Atex zone, protected by explosion vents
- Pneumatic transfer installation
- Cleaning units with vacuum pressure
- Separation of products with high pressure (fine grinding with turbosifter,...)

It can also do a product separation :

- Fines (premix and micronized powders)
- Abrasives (minerals or grains)
- Specific products (starch, chicory, gluten, sunflower cakes, soybean, canola)

Centralised Cleaning

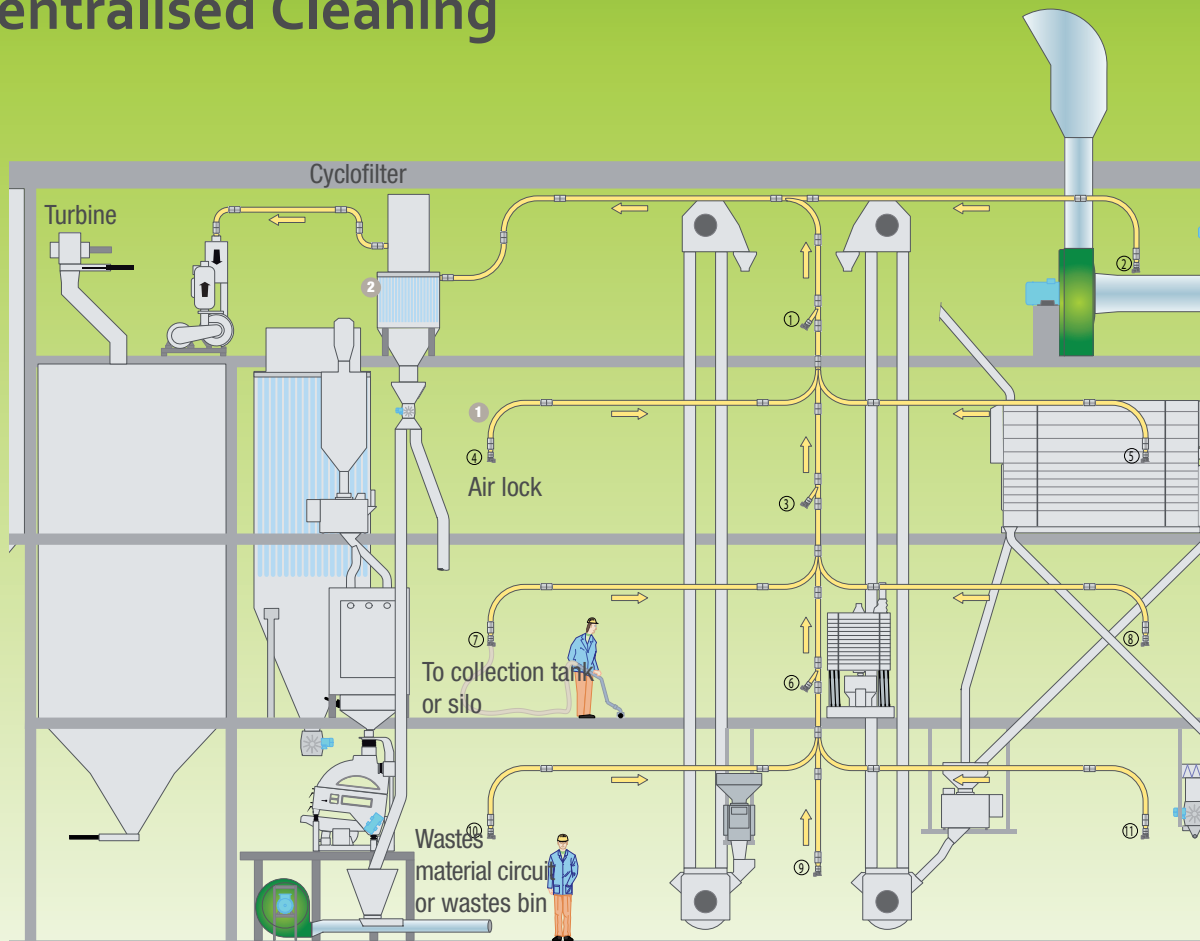

Stolz offers centralised cleaning solutions for long distances and with high vacuum pressure.

Such system includes a suction turbine with a fixed filter plug to a piping network covering the silo or factory.

An operator can clean by vaccuming without effort and without dust emission in all critical zones.

The wastes are continuously discharged to the dust flow path or to good product flow path (overflow recycling) without bags, containers or bins handling.



Centralised Cleaning

Features

Advantages

- Improvement of working conditions
- Easy to use
- Safety

Technical characteristics

- Cyclofilters
- Multistage turbine
- Sealed air lock with pneumatic valves
- Pneumatic handling type piping with high radius elbow
- Assembly by bolted coupling without welding
- Suction inlet with automatic closing flap
- Cleaning accessories

Safety

- ATEX compliance

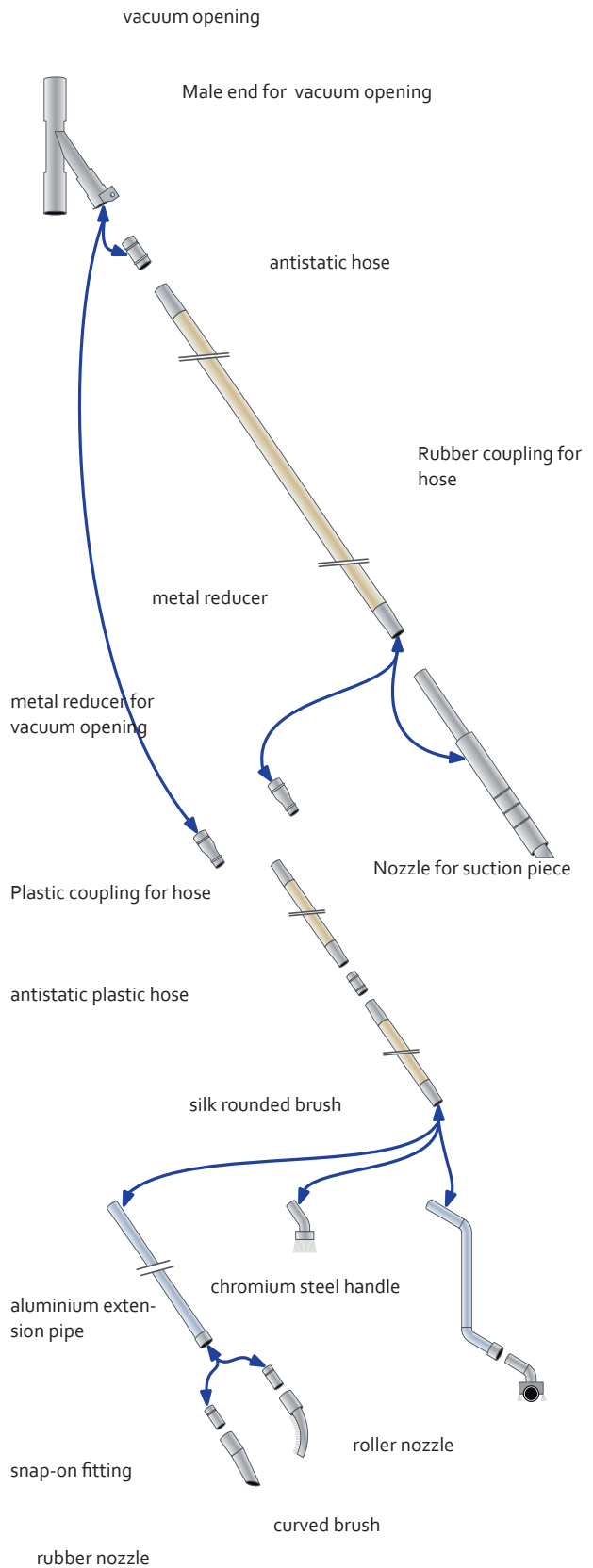



STOLZ

Du végétal à la vie

www.stolz.fr



STOLZ SEQUIPAG SA
82 route de Boisjean - 62170 WAILLY-BEAUCAMP - FRANCE
Tel: + 33 (0)3 21 81 90 05 05 - Fax: + 33 (0)3 21 90 05 15
E-mail : contact@stolz.fr